

Model -SSBH - 300T
THREADED ENDS BSPP / NPT

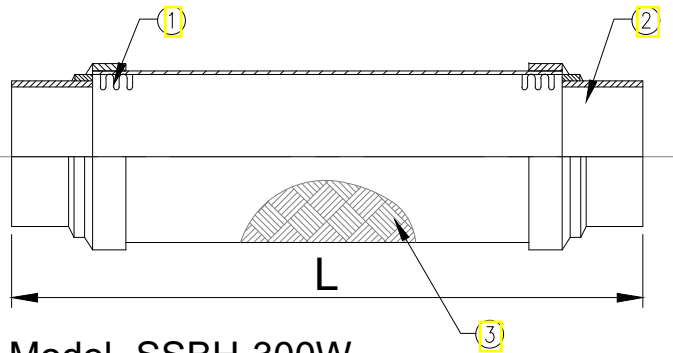

Model -SSBH-300W
STEEL WELD ENDS

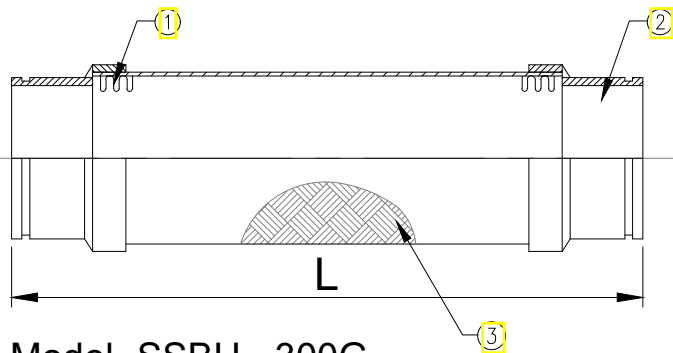

Model -SSBH - 300G
GROOVED ENDS



S.NO.	NOMINAL BORE mm	TOTAL LENGTH (+ / -5mm)			OFFSET (+/-mm)	Working Pressure
		300T	300G	300W		
1.	15	250	250	250	20	20/25
2.	20	250	250	250	20	20/25
3.	25	250	250	250	20	20/25
4.	32	250	250	250	20	20/25
5.	40	250	250	250	16	20/25
6.	50	250	250	250	16	20/25
7.	65	300	300	300	16	16
8.	80	300	300	300	16	16
9.	100	300	300	300	15	16
10.	125	300	300	300	15	16
11.	150	300	300	300	12	16
12.	200	300	300	300	8	16

■ **CONSTRUCTION**

ITEM	PARTS	MATERIAL
1	BELLOWS [300W / G]	SST304
1	BELLOWS [300T]	SST304 / BRONZE [Optional]
2	TUBE [300W/G]	CARBON STEEL/ SS304/ SS316 [Optional]
2	THREADS [300T]	CARBON/BLACK STEEL /SS304
3	BRAID [300W / G]	SST304
3	BRAID [300T]	SST304 / BRONZE [Optional]
4	STANDARD FITTINGS FINISH	GALVO PAINT

Threads Material:

1. DN15-DN50 : SS304
2. NN65 and above : Carbon Steel

OTHER MATERIALS /FINISH AVAILABLE ON REQUEST

Model -SSBH - 300T (THREADED ENDS BSPP / NPT)*

Model -SSBH - 300W (STEEL WELD ENDS)*

Model -SSBH - 300G (GROOVED ENDS)*

* TO SUIT SCH 40 STEEL PIPE

WORKING TEMPERATURE : -50°C to +450°C