

SL. NO. 1 TO 4

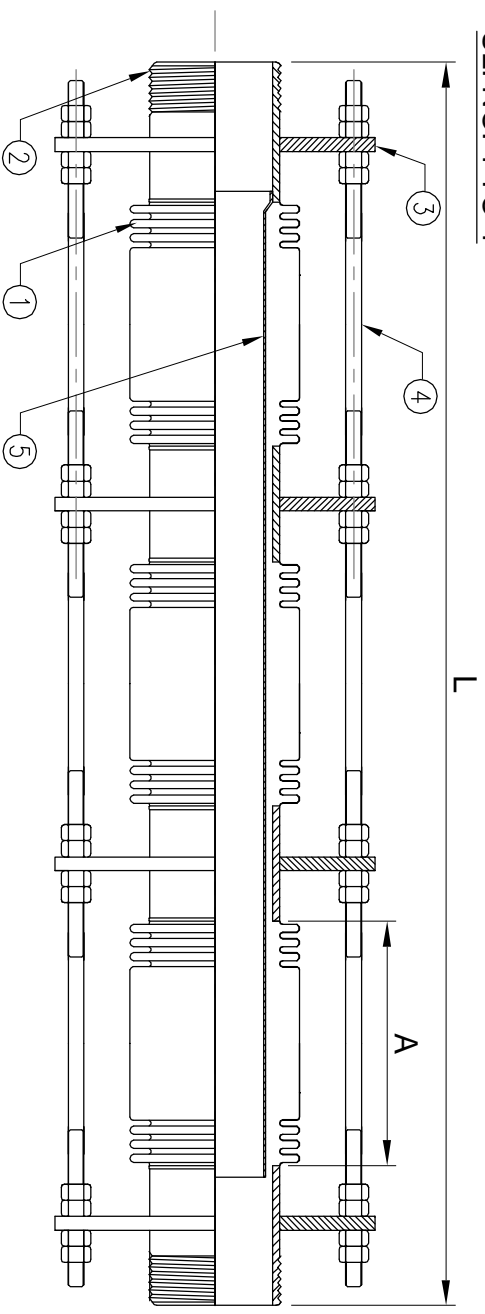

SL. NO. 5

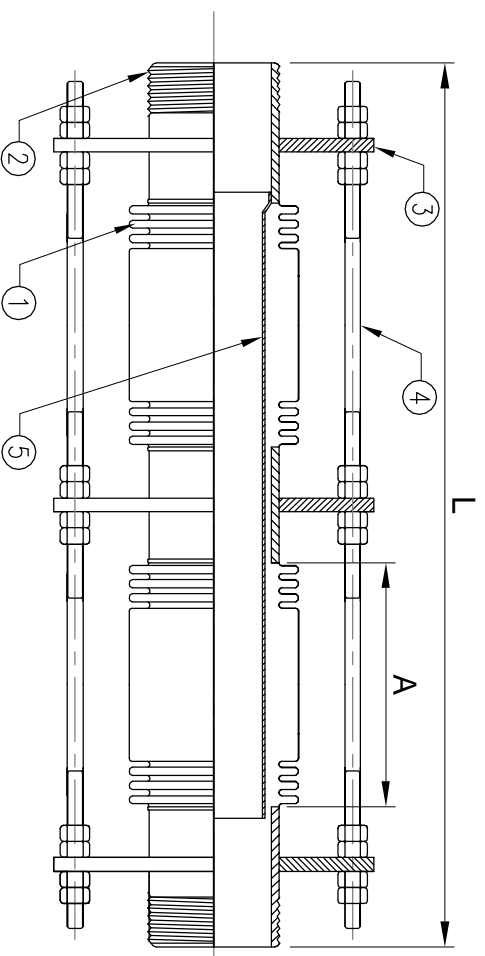

SL. NO.	NOMINAL BORE	TOTAL LENGTH (L)	BELLOWS	
	mm	(+/-5mm)	CORRS	A
1	20	650	22+22+22	115
2	25	650	22+22+22	115
3	32	680	20+20+20	140
4	40	680	20+20+20	150
5	50	650	26+26	190

LARGER SIZES ON REQUEST

■ CONSTRUCTION		
ITEM	PARTS	MATERIAL
1	BELLOWS	SST304 (2 PLY)
2	TUBE	CARBON STEEL
3	GUSSET	CARBON STEEL
4	TIE RODS	CARBON STEEL
5	INNER SLEEVE	SST304
6	FLANGE	CARBON STEEL

OTHER MATERIALS/FINISH AVAILABLE ON REQUEST

STANDARD FINISH
 FLANGES / GUSSETS : GALVO PAINT
 CONTROL ROD : ZINC PLATED
 & HARDWARE

Model - SSEJ-250T-SG
 THREADED ENDS - BSPP / NPT

WORKING PRESSURE : 25 bar
 WORKING TEMPERATURE : -50°C to +450°C
 AXIAL MOVEMENT : + / - 50mm



Kinjoints
 Stainless Steel Expansion Joints

DRG. NO. : SSEJ/250T/20-50/02