

**Specification:**

Working Pressure: 17 Bar(250psi)

Working Temperature: -20 Degree C to 90 Degree C

Application: hot water storage tanks, water and air conditioners, processing tanks, steam, gas, and water piping ect.

**Standards:**

Thread: NPT thread as per ASME B1.20.1/ G thread as per ISO 228/1

Solder : ASME B16.18

**M x C Series DU---Steel Male NPT /G Thread x Brass Solder**

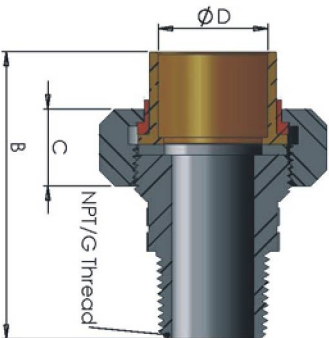
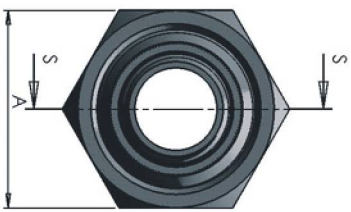

Material		
No.	Part Name	Material
1	Steel Nut	Forged Steel
2	Plastic Sleeve	Nylon
3	Brass/Steel Tailpiece	Forged Brass / Steel
4	Rubber Washer	NBR
5	Steel Tailpiece	Forged Steel

Item No.	Size	A mm	B mm	C mm	D mm	Thread
DU050MC	1/2"	36	70	19.5	16.0	1/2"
DU065MCR	3/4"x1/2"	41	74	19.5	16.0	3/4"
DU075MC	3/4"	41	77	19.5	22.4	3/4"
DU100MC	1"	48	82	20	28.7	1"

