

CIRCULAR IN-LINE DUCT CENTRIFUGAL FAN-PAINTED SHEET METAL

KINAIR Circular In-line Duct Fan has an all-metal material with strong anti-corrosion ability. Fan body is made of Eco-friendly material with compact design. Backward inclined type of Impeller design, Optimization of air duct, Ensure continuous and high efficient air supply, air volume supply is adequate.

The fan speed can be controlled by voltage or frequency variation regulators.

IP44 protection and F-class insulation external rotor motor, which is more durable and ball bearing with long working life over 50000 hours.

Operating temperature range: -20°C to 70°C



BODY STRUCTURE

Available with AC motor or EC motor

Adopt self-developed F-class insulation motor, which is more durable

EC PCB

The new casing is more compact and more rational on the molding line, which greatly improves the efficiency of the fan

High pressure, suitable for long distance air supply

Full metal with powder coated surface, Precise anti-rust treatment, strong corrosion resistance

PERFORMANCE CURVE

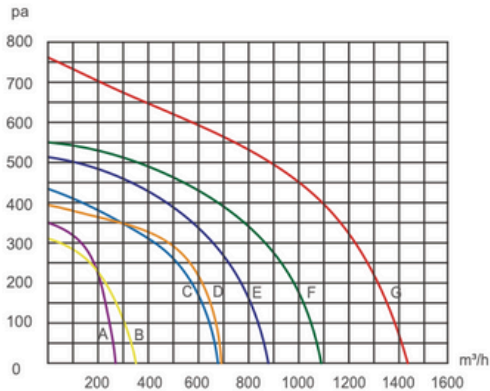

A:KVF-100M
B:KVF-125M
C:KVF-150M
D:KVF-160M
E:KVF-200M
F:KVF-250M
G:KVF-315M

AC Motor

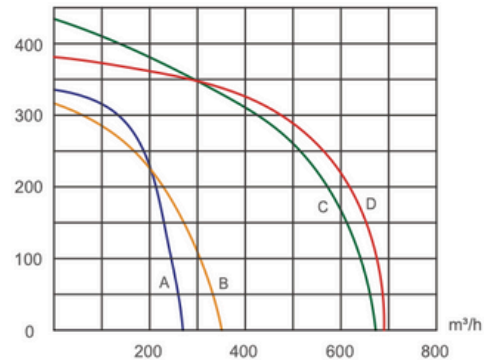

A:KVF-100M-E
B:KVF-125M-E
C:KVF-150M-E
D:KVF-160M-E

EC Motor

UNIT SIZE AND PARAMETERS

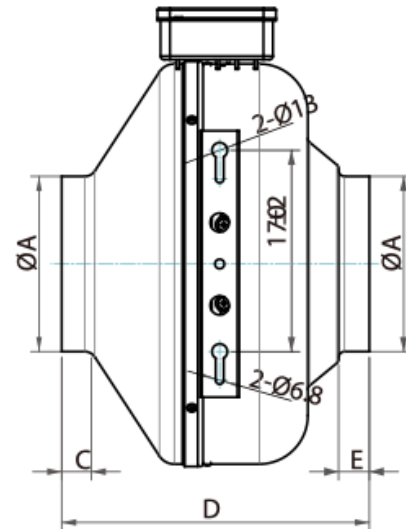
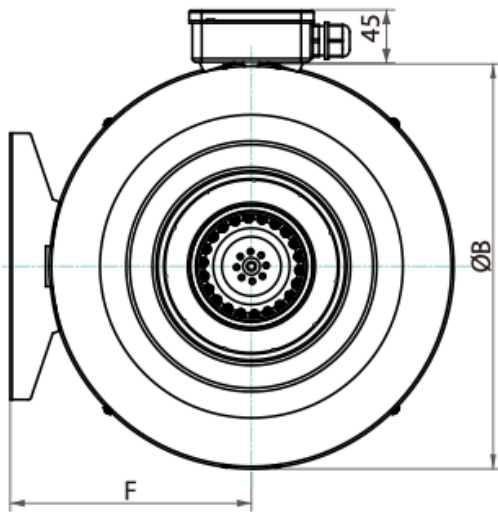

AC Motor

Voltage/Frequency:220V/50Hz

Unit: mm

Model	ΦA	ΦB	C	D	E	F	Specification	Input power (W)	Air Volume (m³/h)	Noise (dB)	Static Pressure (Pa)	Rotation Speed (rpm)	Net Weight (kg)	Gross Weight (kg)	Duct Dimension (mm)	Applicable Area (m³)	Package Size (mm)
KVF-100MR	98	272	20	190	21	169	190	45	270	65	350	2400	2.8	3.5	Φ95	6-13	330x320x225
KVF-125MR	123	272	20	190	21	169	190	45	350	65	310	2400	2.8	3.5	Φ125	13-18	330x320x225
KVF-150MR	148	342	25	260	26	204	220	104	675	65	430	2400	5.0	5.9	Φ150	18-32	405x390x275
KVF-160MR	158	342	25	260	26	204	220	98	685	68	390	2500	5.0	5.9	Φ160	32-40	405x390x275
KVF-200MR	198	342	25	240	36	204	250	122	940	69	530	2550	5.8	6.7	Φ200	40-50	405x390x275
KVF-250MR	248	342	25	240	36	204	250	133	1090	70	550	2550	5.8	6.7	Φ250	50-60	405x390x275
KVF-315MR	313	382	40	240	40	225	280	180	1430	71	760	2500	7.0	8.2	Φ315	60-70	445x435x255